

SECTION - 1

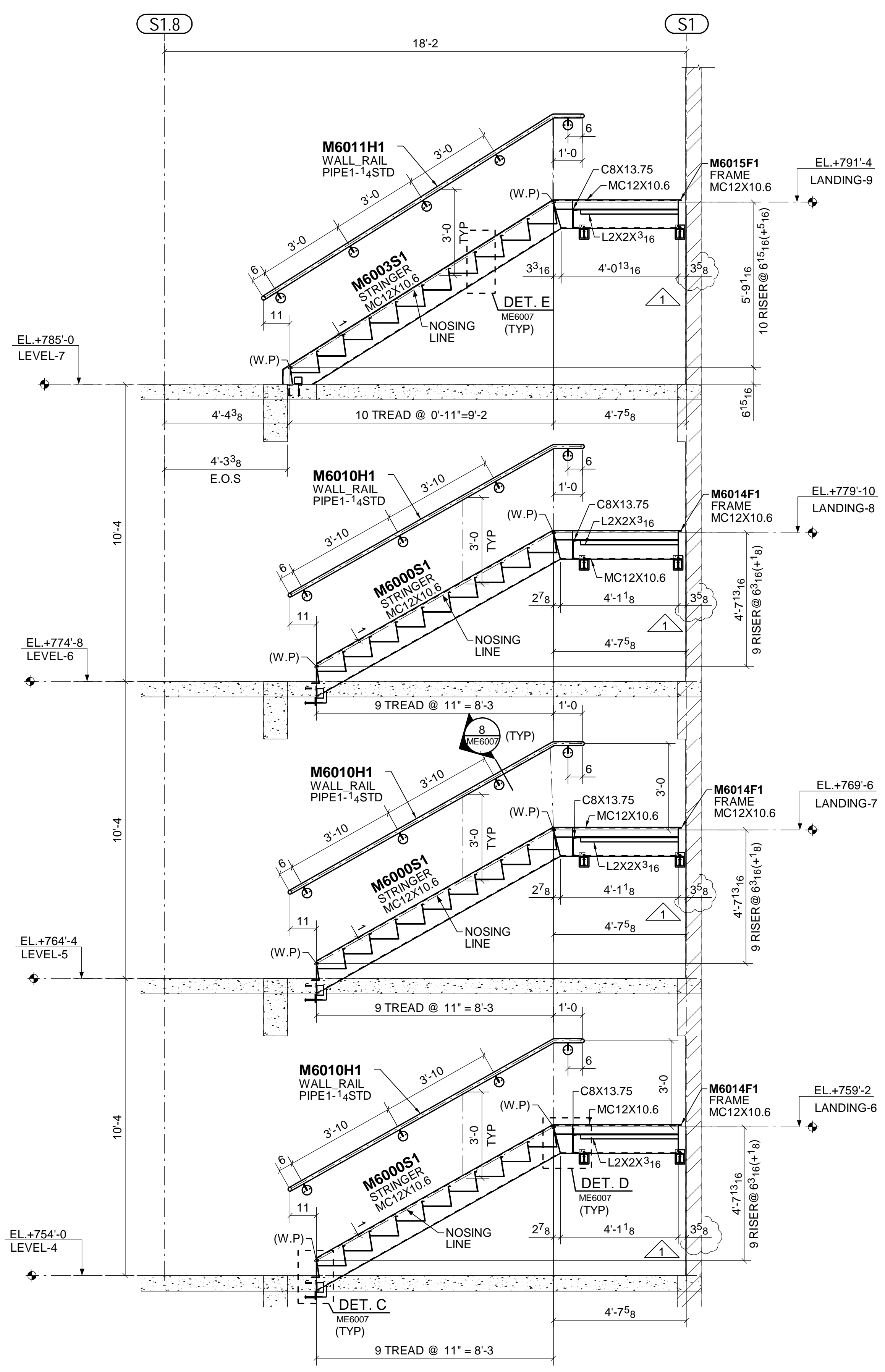

SECTION - 2

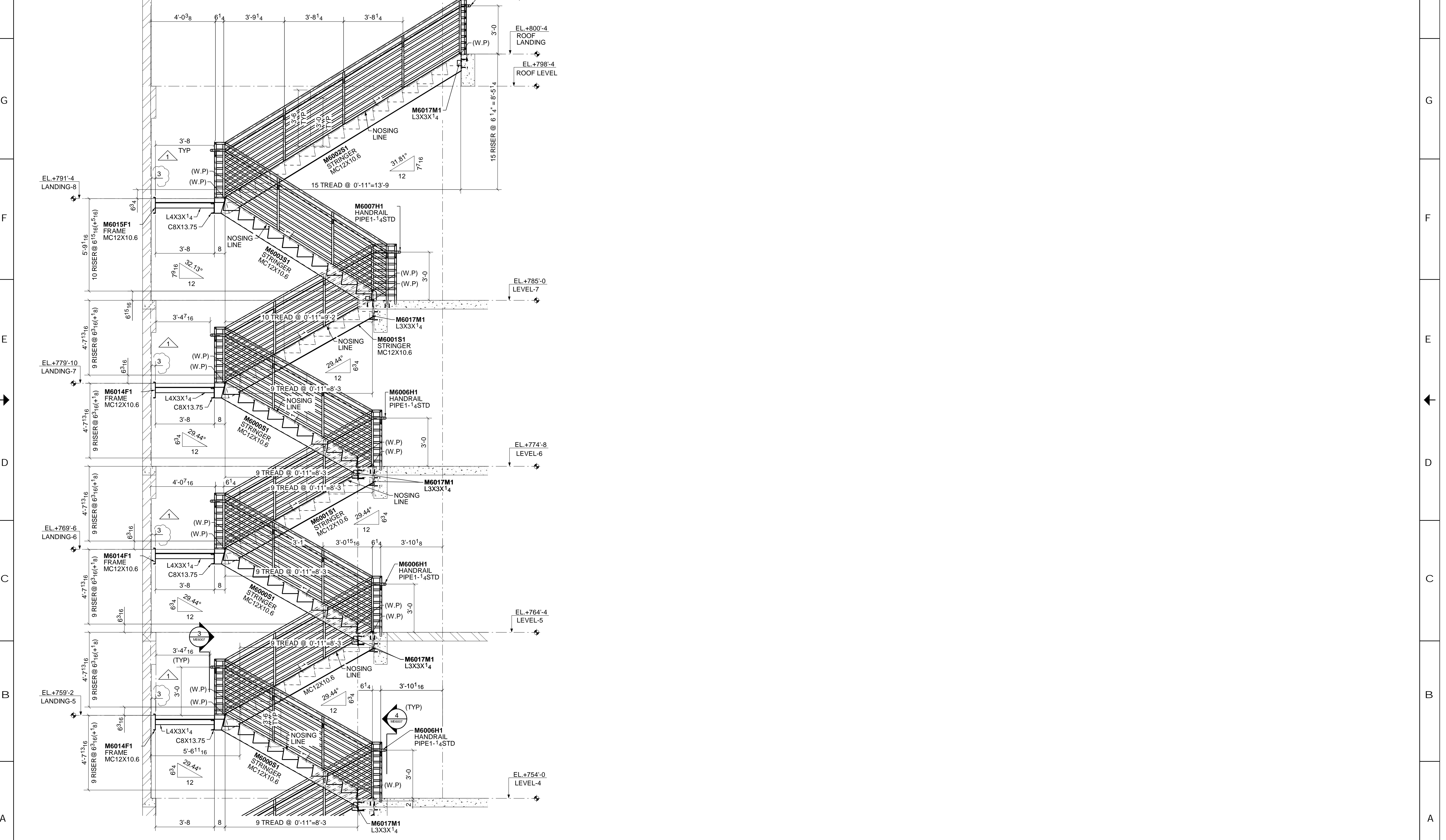

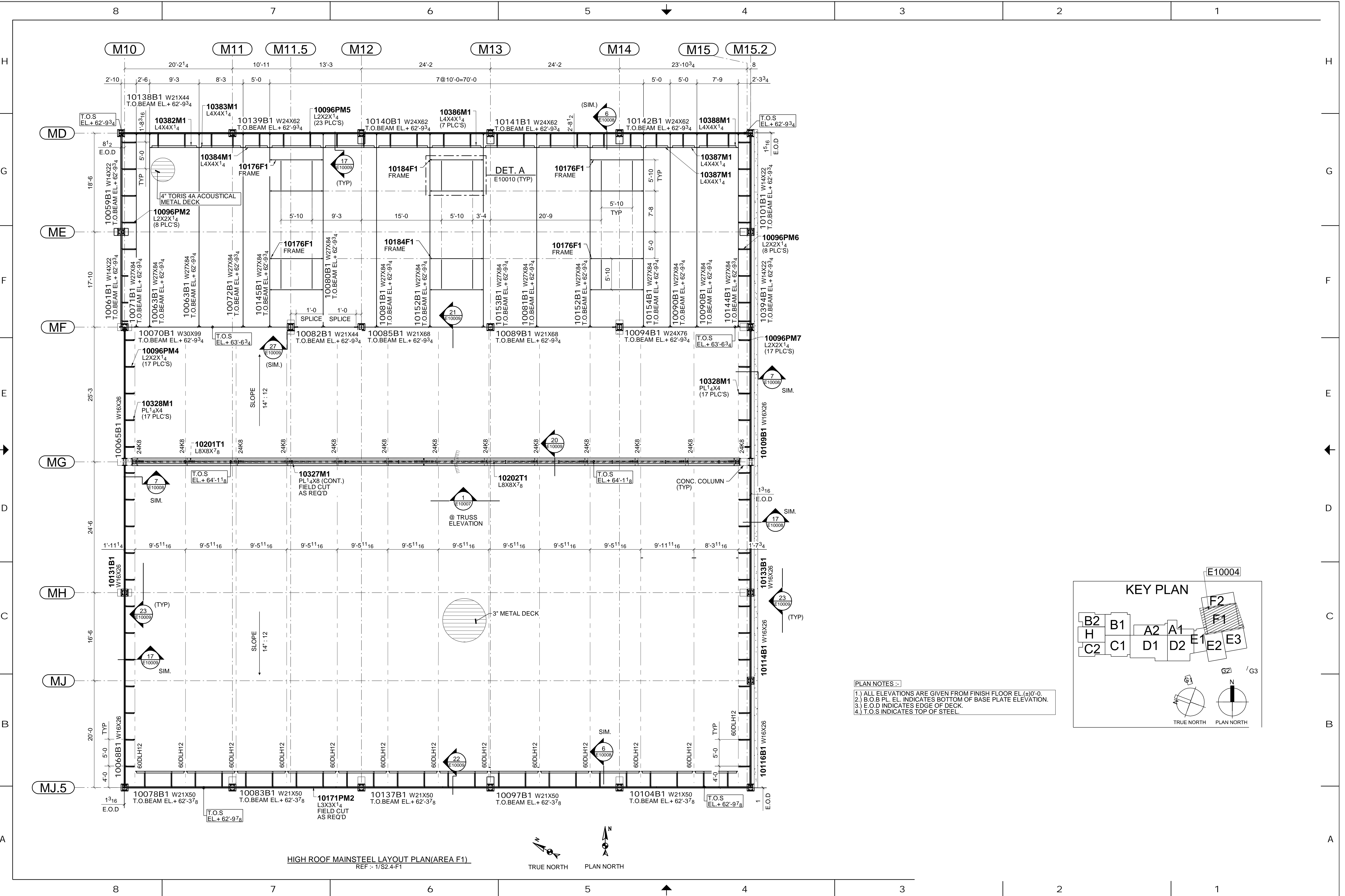

HIGH ROOF MAINSTEEL LAYOUT PLAN (AREA F1)  
REF: 1/S2.4-F1

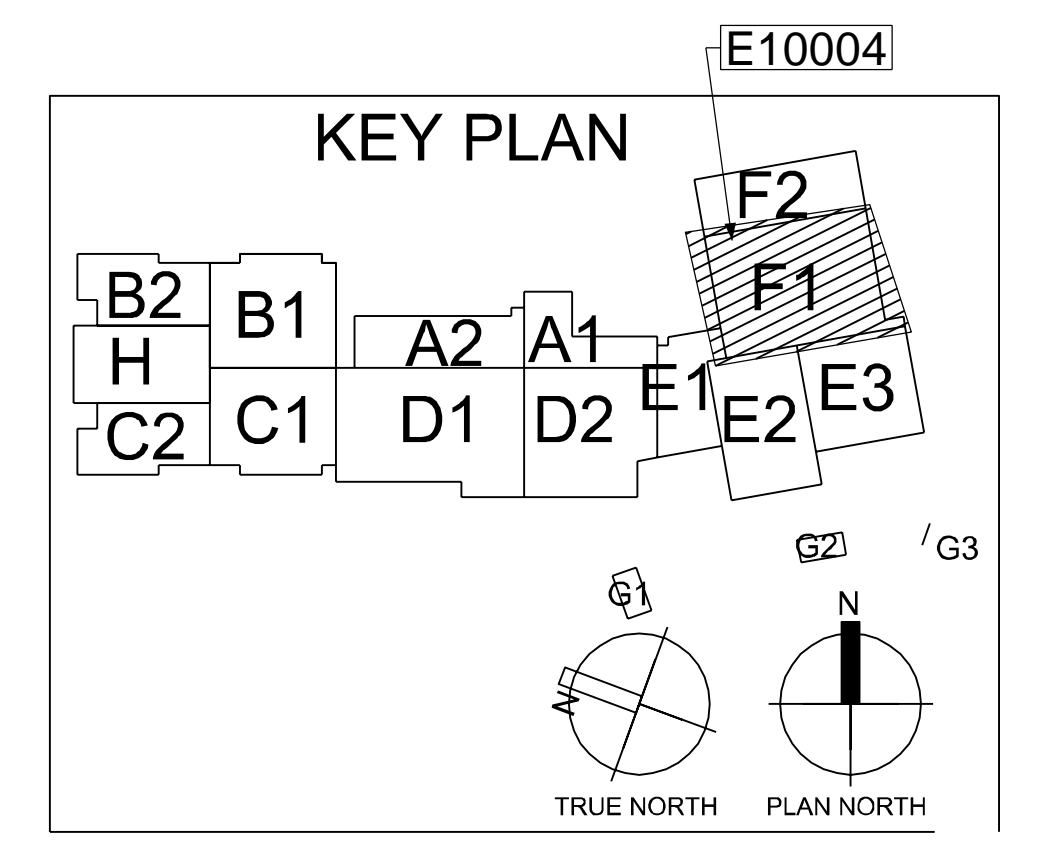
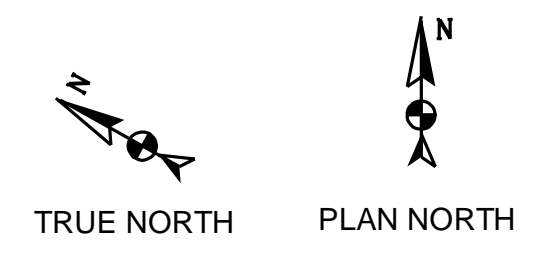

- PLAN NOTES :-
- 1.) ALL ELEVATIONS ARE GIVEN FROM FINISH FLOOR EL.(±)0'-0.
  - 2.) B.O.B PL. EL. INDICATES BOTTOM OF BASE PLATE ELEVATION.
  - 3.) E.O.D INDICATES EDGE OF DECK.
  - 4.) T.O.S INDICATES TOP OF STEEL.



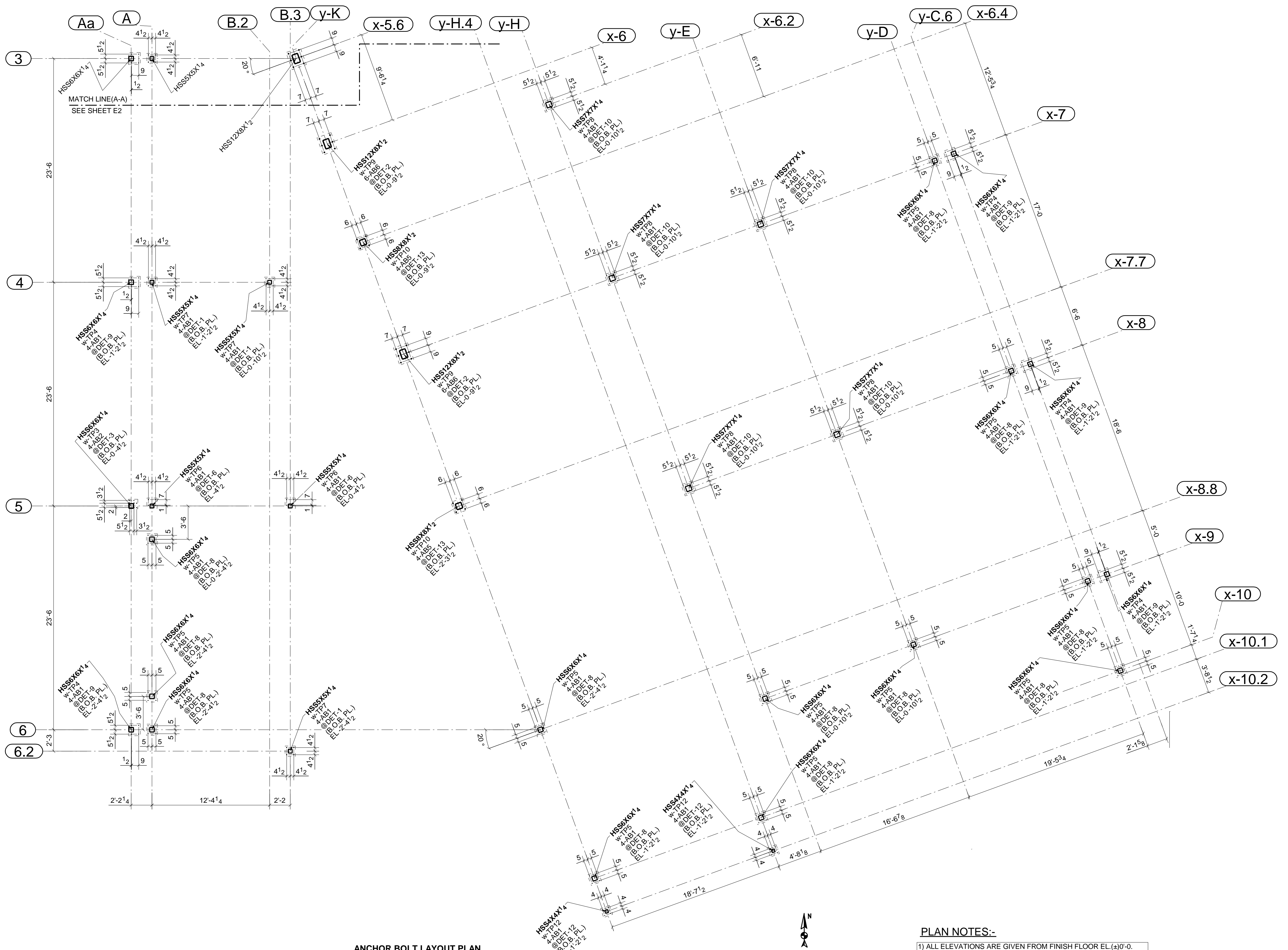

**ANCHOR BOLT LAYOUT PLAN**  
(REF:-1.01)



**PLAN NOTES:-**

- 1) ALL ELEVATIONS ARE GIVEN FROM FINISH FLOOR EL. (+)0'-0"
- 2) B.O.B PL. EL. INDICATES BOTTOM OF BASE PLATE ELEVATION

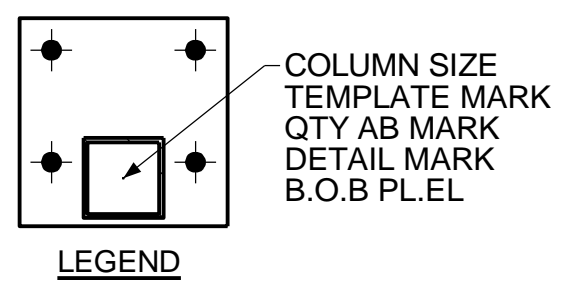

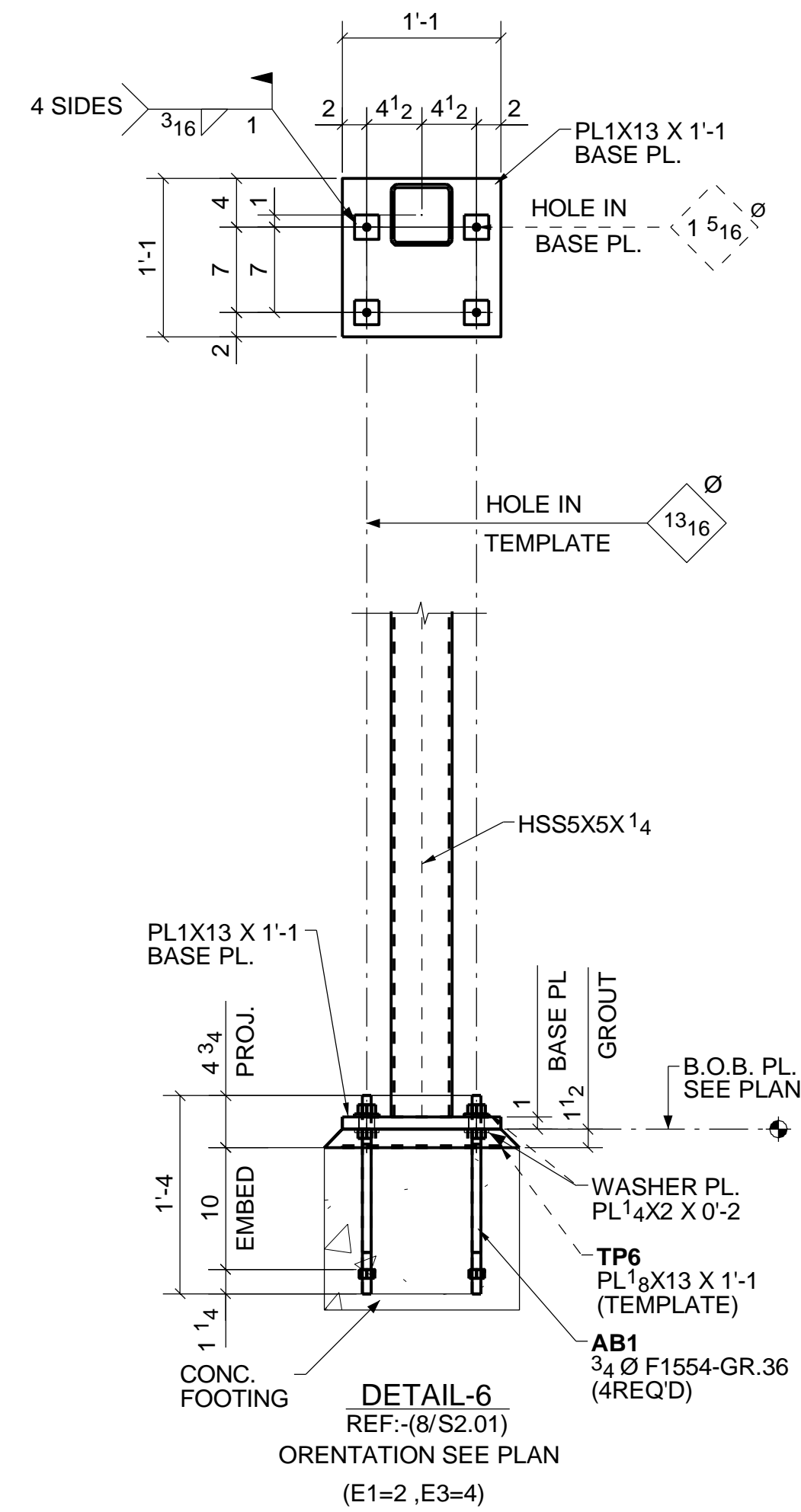
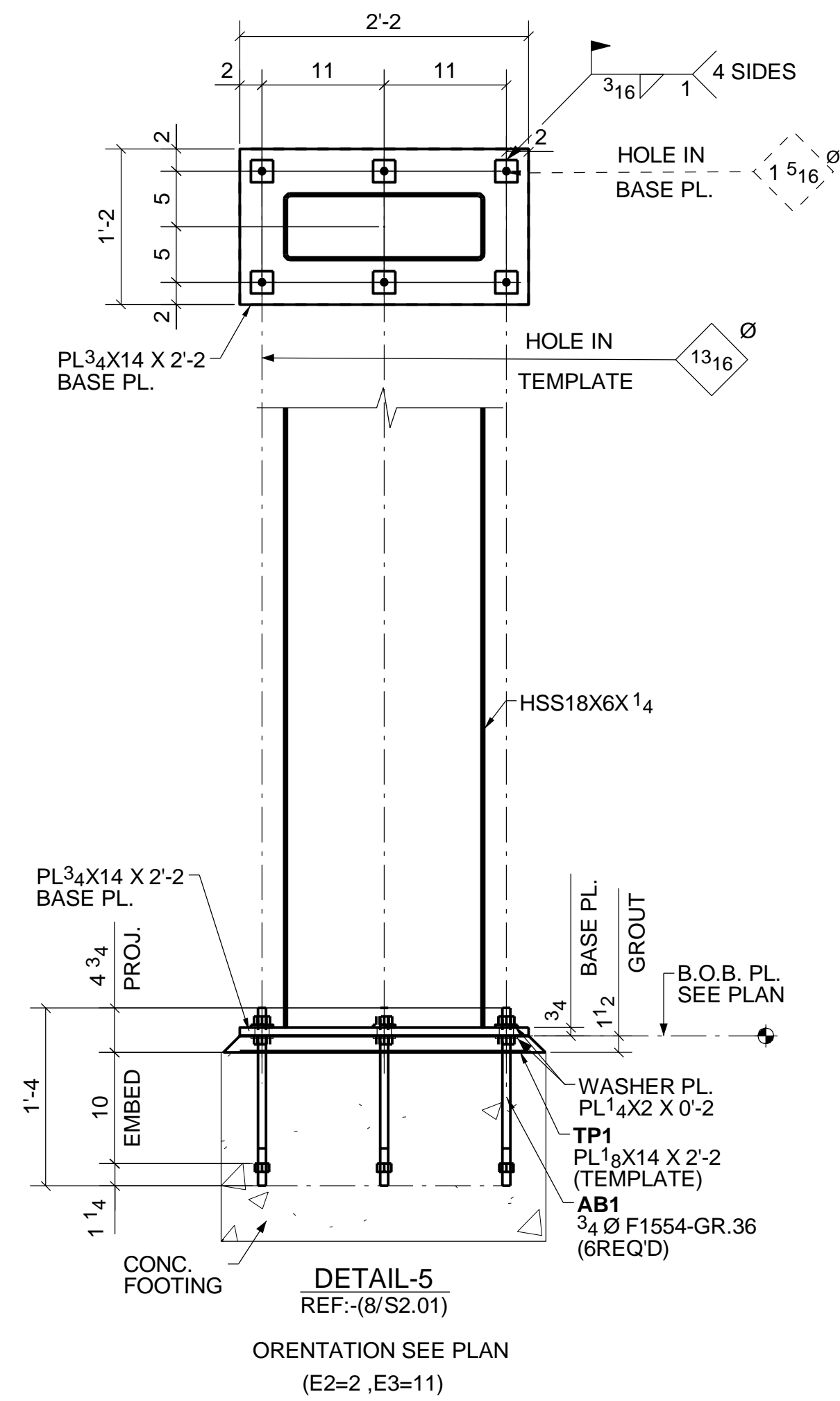
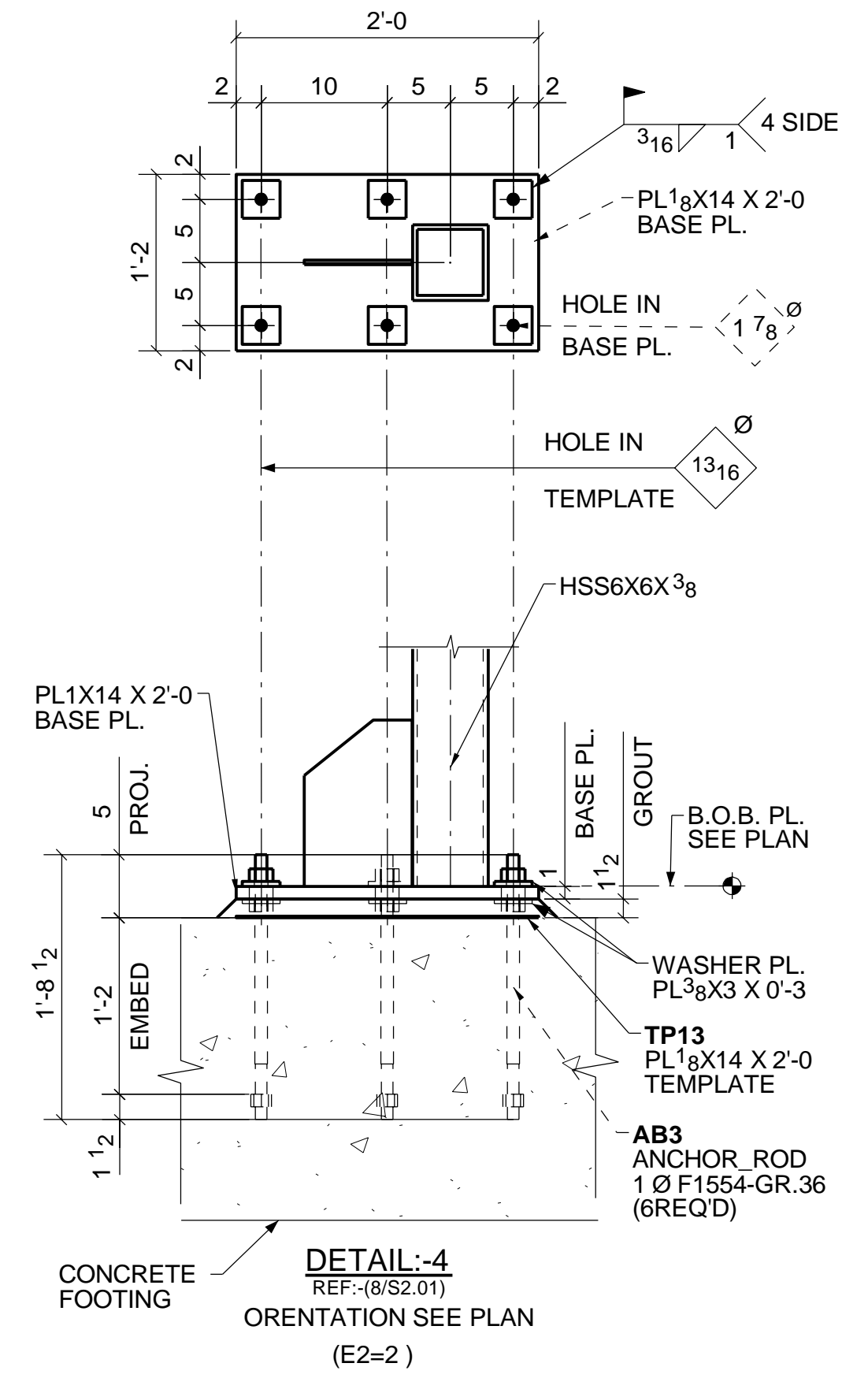
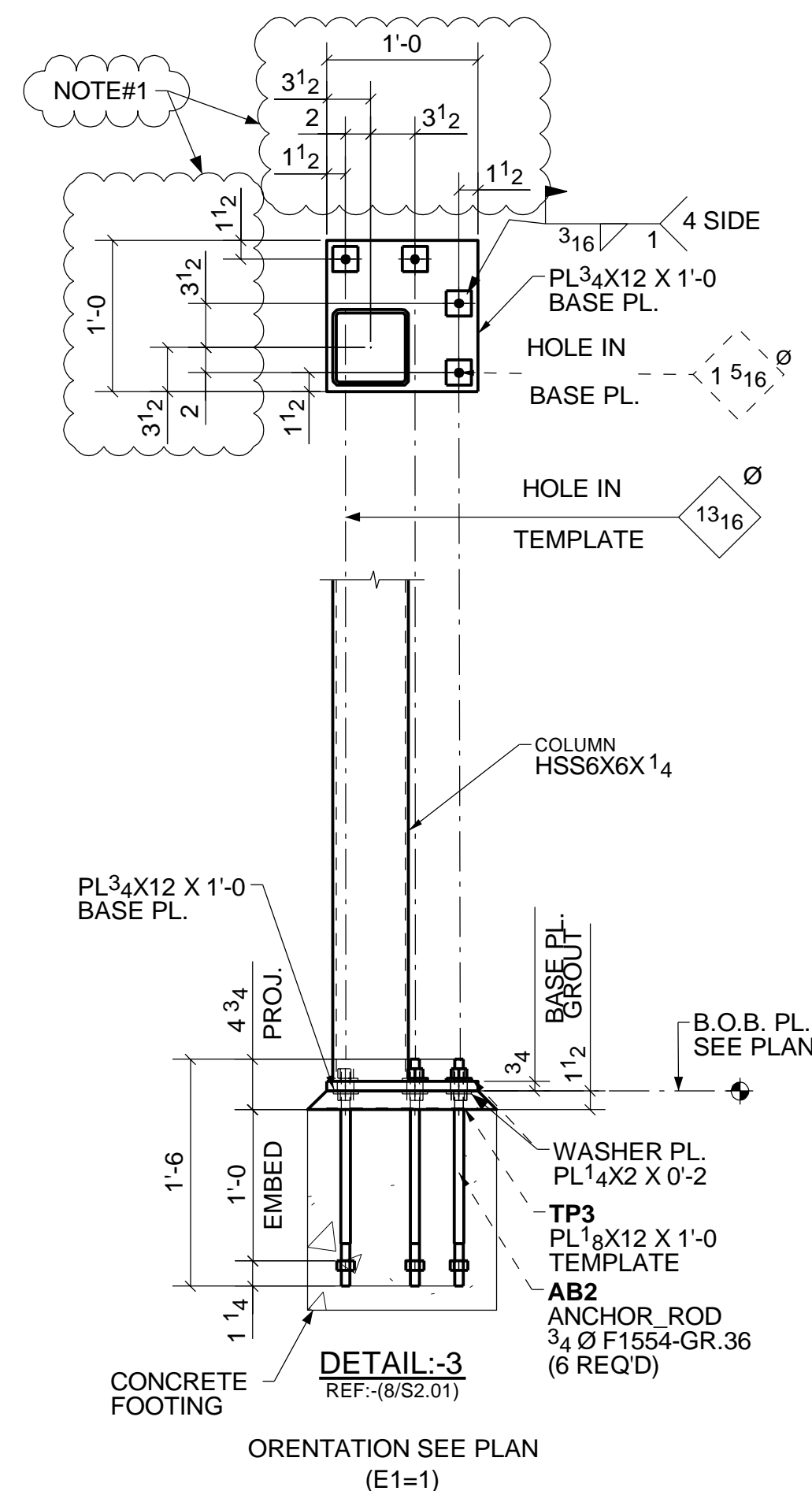
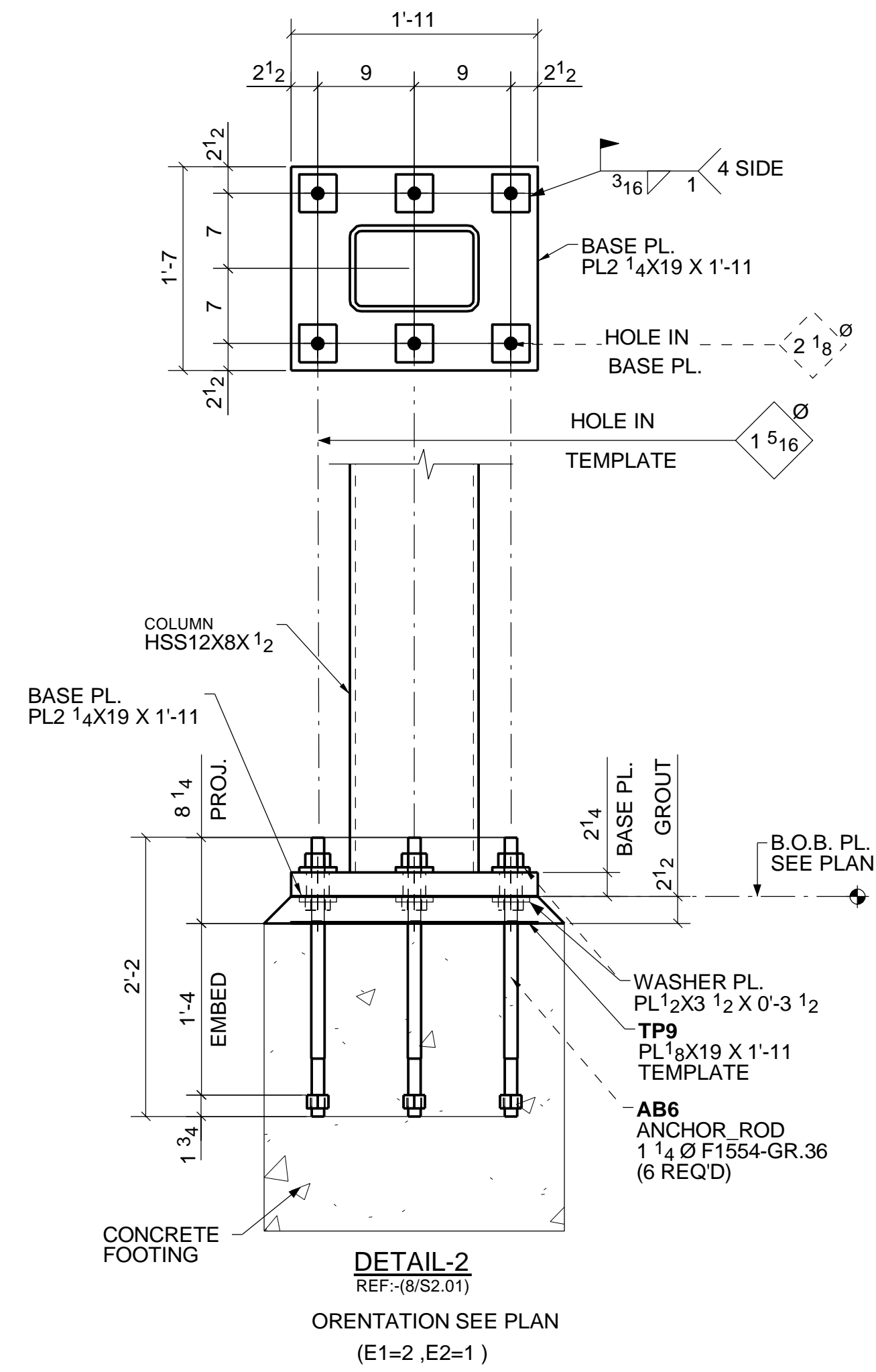
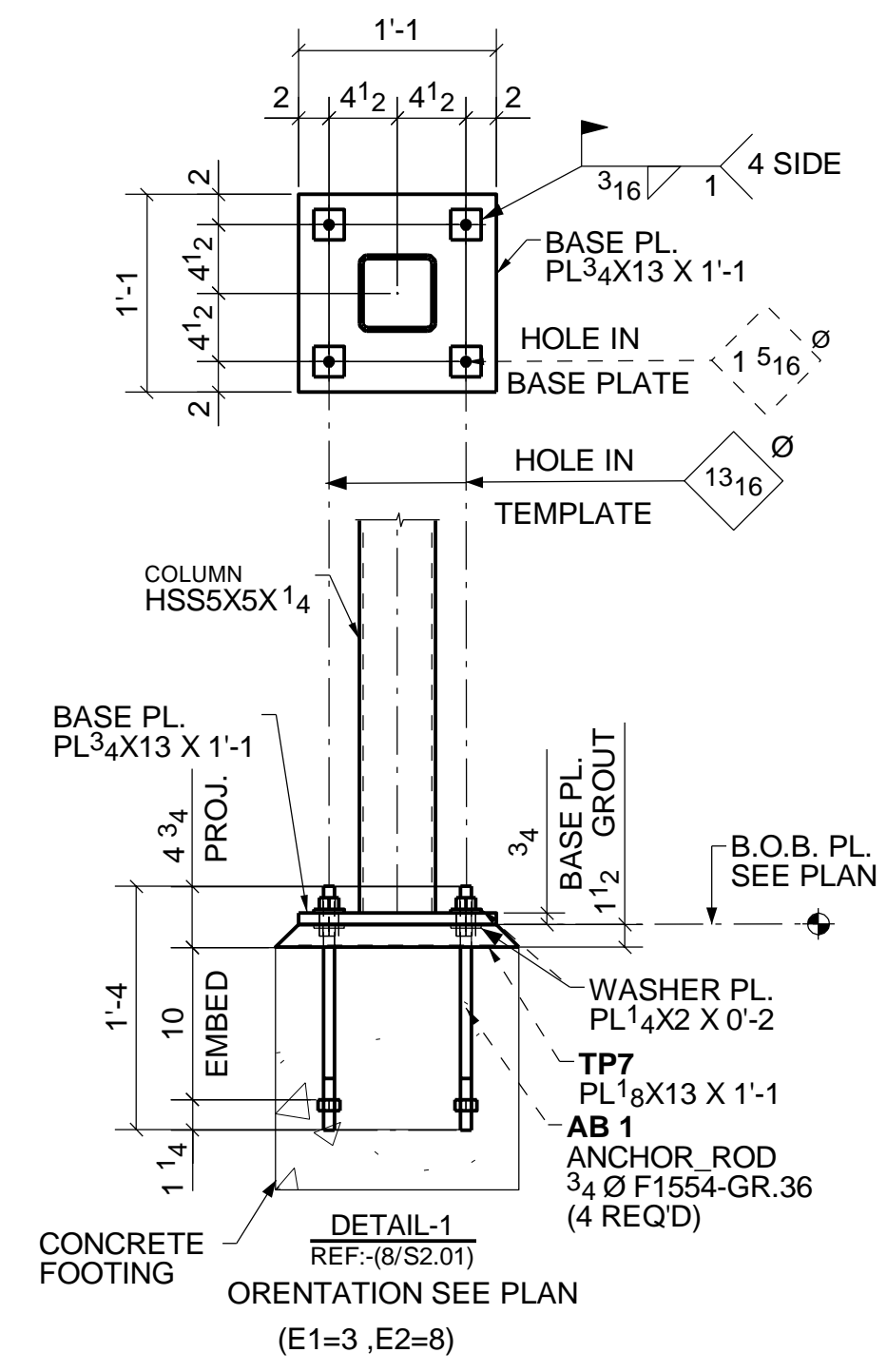

**APPROVER NOTES:-**

NOTE#1:- PLAASE VERIFY OR PROVIDE FIXING DIMENSION OF COLUMN TO BASE PLATE

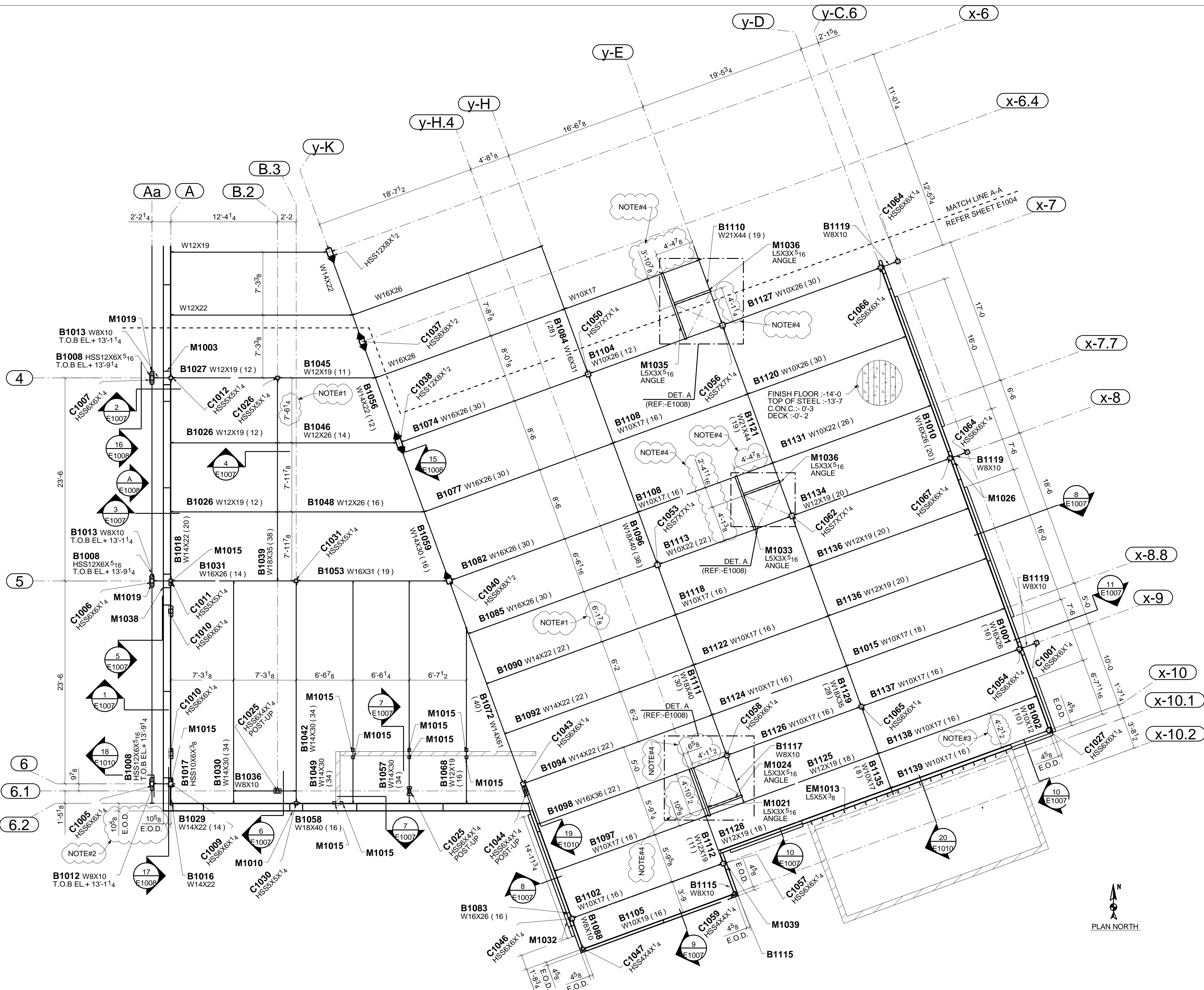

SHEAR STUD SCHEDULE			
QTY.	DIA	LENGTH	MATERIAL
916	3/4"	37"	A108

APPROVER NOTES:-

NOTE#1:- THERE IS A CONFLICT IN DIMENSION PLEASE VERIFY/ PROVIDE CLOUDED FIXING DIMENSION.  
 NOTE#2:- PLEASE VERIFY/ PROVIDE CLOUDED FIXING DECK EDGE.  
 NOTE#3:- PLEASE VERIFY CLOUDED DIMENSION.  
 NOTE#4:- PLEASE VERIFY AND PROVIDE FIXING DIMENSION OF OPENING.

PLAN NOTES:-

1). ALL ELEVATION ARE GIVEN FROM FINISH FLOOR 0'-0"= 100'-0"  
 2). T.O.S.EL. INDICATES TOP OF STEEL ELEVATION.  
 3). E.O.D INDICATES EDGE OF DECK.  
 4). T.O.B.EL INDICATES TOP OF BEAM ELEVATION.

2ND FLOOR STEEL LAYOUT PLAN  
 (T.O.S. EL.+13'-7") (UNO)  
 (REF:-S1.03)



# BILL OF MATERIAL

MARK	QTY	DESCRIPTION	LENGTH	WEIGHT	REMARKS
B3008	1	BEAM			SQ-2
B3008	1	W14X30	15'-5 3/4"	466	NO PAINT A992
p43	1	PL3/8X12 1/2	7'-9 3/16"	124	A36
p66	1	PL3/8X12 1/2	7'-9 3/16"	124	A36
p74	2	PL3/8X3 1/4	1'-1"	9	A36
p81	1	PL3/8X4	0'-9"	4	A36
p93	1	PL3/8X3 1/4	1'-1 1/8"	4	A36
p192	12	PL1/4X4	0'-4"	14	A36
TOTAL WEIGHT THIS DRAWING				745	

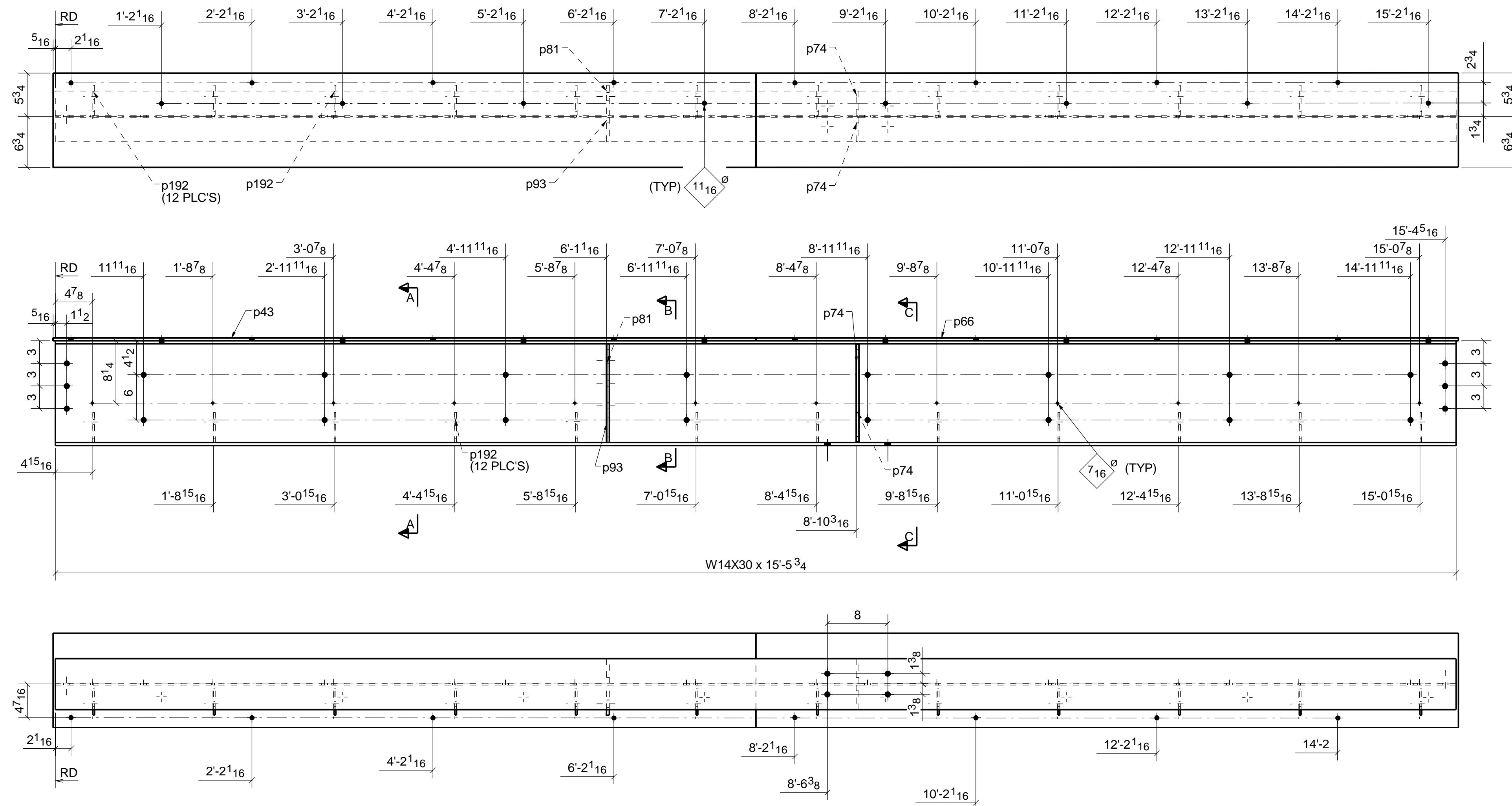
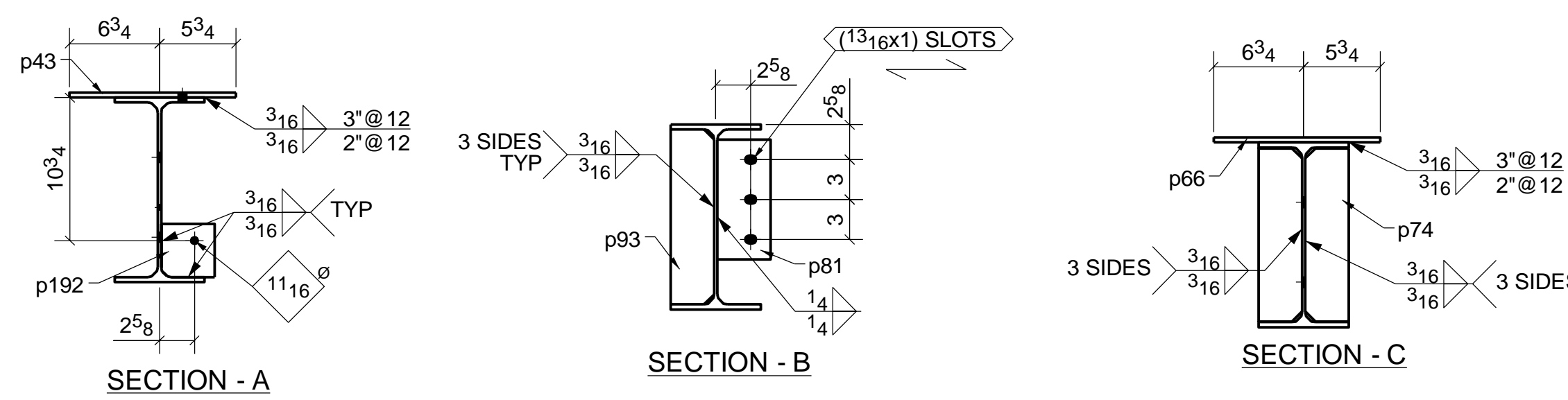

	INITIAL	DATE
<input type="checkbox"/> CUT PIECE		
<input type="checkbox"/> LAYOUT		
<input type="checkbox"/> CHECK LAYOUT		
<input type="checkbox"/> FAB		
<input type="checkbox"/> CHECK FAB		
<input type="checkbox"/> WELD OUT		
<input type="checkbox"/> FULL INSPECTION		

ONE ~ BEAM ~ B3008



ONE QTY @ E3039

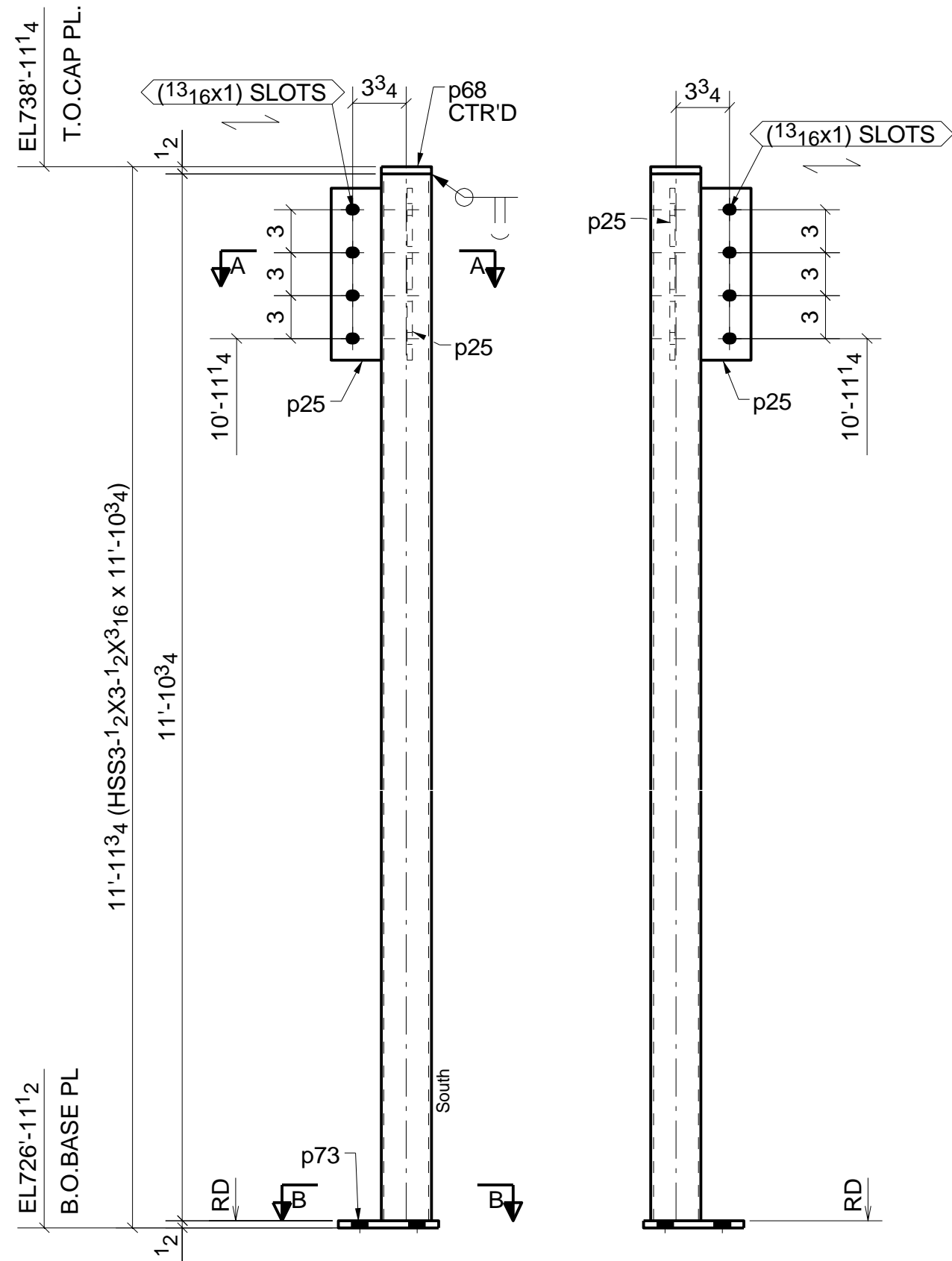

ONE ~ COLUMN ~ C3044

### BILL OF MATERIAL

MARK	QTY	DESCRIPTION	LENGTH	WEIGHT	REMARKS
C3044	1	COLUMN			SQ-2
C3044	1	HSS3-1/2X3-1/2X3/16	11'-10 3/4	91	NO PAINT A500-GR.C
p25	2	PL3/8X3 1/2	1'-0	9	A36
p68	1	PL1/2X3 1/2	0'-3 1/2	2	A36
p73	1	PL1/2X7	0'-7	7	A36
TOTAL WEIGHT THIS DRAWING				108	

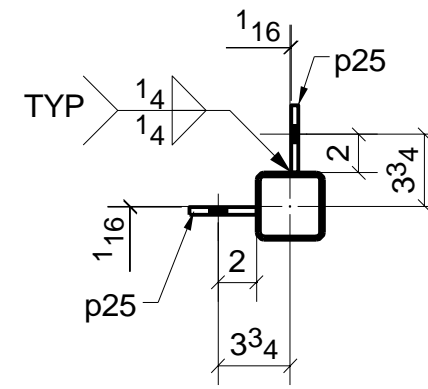

SECTION - A

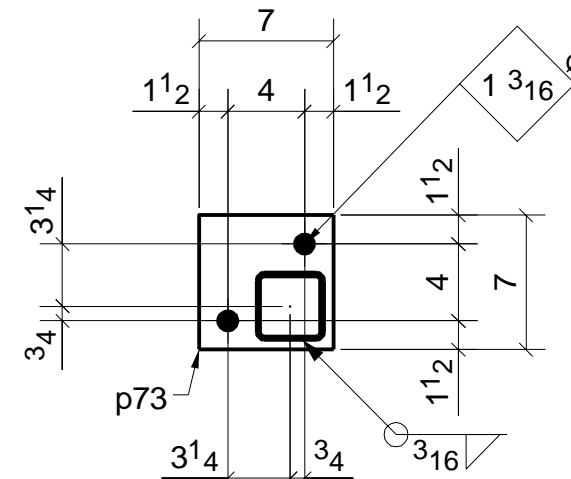

SECTION - B